

FRANTUMATORE MULTI KIT - MULTI KIT PULVERIZER BROYEUR MULTI KIT - DEMOLEDOR MULTI KIT MEHRZWECKGERÄT MULTI KIT

		MK 10	MK 15	MK 20	MK 25	MK 35
(1)	t.	9 : 18	18 : 25	25 : 35	35 : 45	45 : 60
	kg.	600	1180	1465	1970	2150
H1**	mm.	1000	1220	1480	1530	1545
	bar	310	310	310	310	310
	l/min.	150 / 250	180 / 250	200 / 300	250 / 350	300 / 400
	bar	140	140	140	140	140
	l/min.	10	10	10	10	10

Serie **MK**

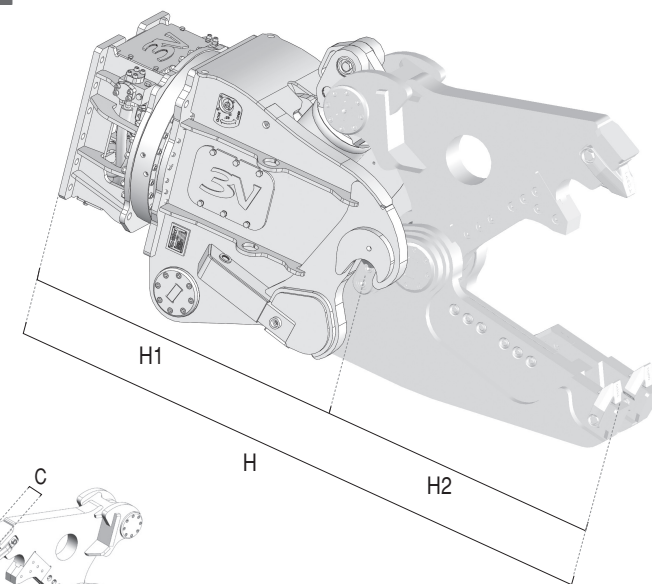

(**) H = H1 + H2

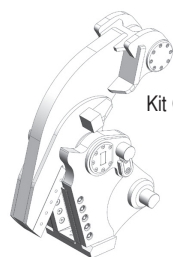

Kit CL*

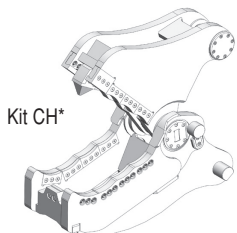

Kit CH*

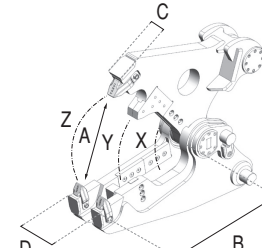
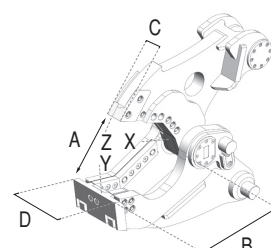
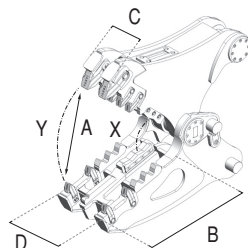

*Disponibile su richiesta - *Available on request - *Disponible sur demande - *Disponible a petición - *Verfügbar auf Anfrage

		Kit FR					Kit CS					Kit CB				
		MK 10	MK 15	MK 20	MK 25	MK 35	MK 10	MK 15	MK 20	MK 25	MK 35	MK 10	MK 15	MK 20	MK 25	MK 35
	kg.	410	680	1010	1200	1720	360	630	950	1160	1345	450	720	1080	1250	1690
A	mm.	660	740	880	905	970	340	420	480	500	510	580	740	810	850	880
B	mm.	580	660	790	820	860	400	470	525	560	565	560	720	800	810	875
C	mm.	220	300	310	360	390	75	100	120	130	130	100	110	130	130	130
D	mm.	430	470	485	570	640	300	330	380	435	435	290	320	350	410	410
	mm.	140	220	260	260	260	370	450	510	565	565	350	420	480	500	500
H2**	mm.	780	840	1045	1100	1210	630	775	890	935	990	800	1000	1125	1165	1255
X	t.	85	190	205	230	330	250	420	530	720	740	220	420	510	700	740
Y	t.	40	65	80	105	115	100	180	230	290	315	60	100	125	155	175
Z	t.	/	/	/	/	/	60	95	120	145	160	40	65	80	100	115
∅ max	mm.	25	35	40	45	50	35	50	60	65	70	30	40	45	50	55
IPN max	mm.	/	/	/	/	/	120	210	360	380	400	/	/	/	/	/
HEA max	mm.	/	/	/	/	/	100	140	230	250	260	/	/	/	/	/
max	mm.	/	/	/	/	/	/	/	/	/	/	/	/	/	/	/

(1) Accoppiamento escavatore-attrezzatura consigliato / (1) Excavator-equipment recommended combination / (1) Couplage pelle-équipement recommandé / (1) Acomplamiento excavadora-ítem recomendado / (1) Empfohlene Kombination von Bagger und Ausrüstung

